

UM-3 Direct Mount Series

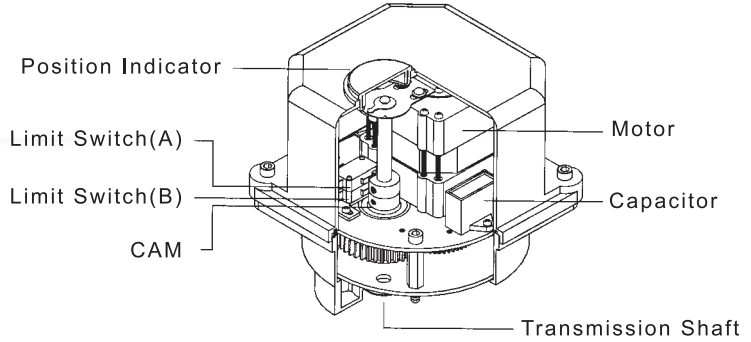

Weight : 4.2 kg



| Power | Specification | | | Speed(sec) | | Output Torque Kgf-cm | | |
|-------|---------------|--------|-------|------------|-----|----------------------|--------|-------|
| | 110VAC | 220VAC | 24VDC | AC | DC | 110VAC | 220VAC | 24VDC |
| 25W | 0.76A | 0.42A | N/A | 1 | N/A | 294 | 350 | N/A |
| | | | | 8 | | 1486 | 1562 | |
| 30W | N/A | | 0.5A | N/A | 1 | N/A | | 506 |
| | | | | | 8 | | | 1660 |

| The Size Of Valve | | | |
|-------------------|--------------|-----------------|-------------|
| Screwed Ends | Flanged Ends | Butterfly Valve | 3-Way Valve |
| 1 1/4" ~ 3" | 1 1/4" ~ 3" | 2" ~ 4" | 2 1/2" |

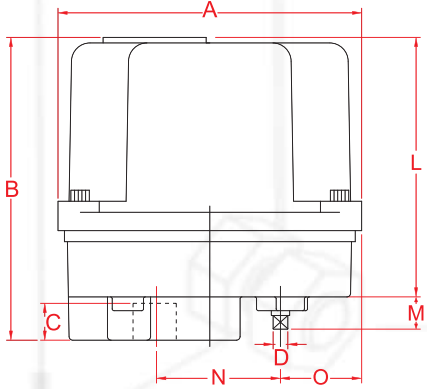

*The UM-3/24VDC is over standard height 26mm.

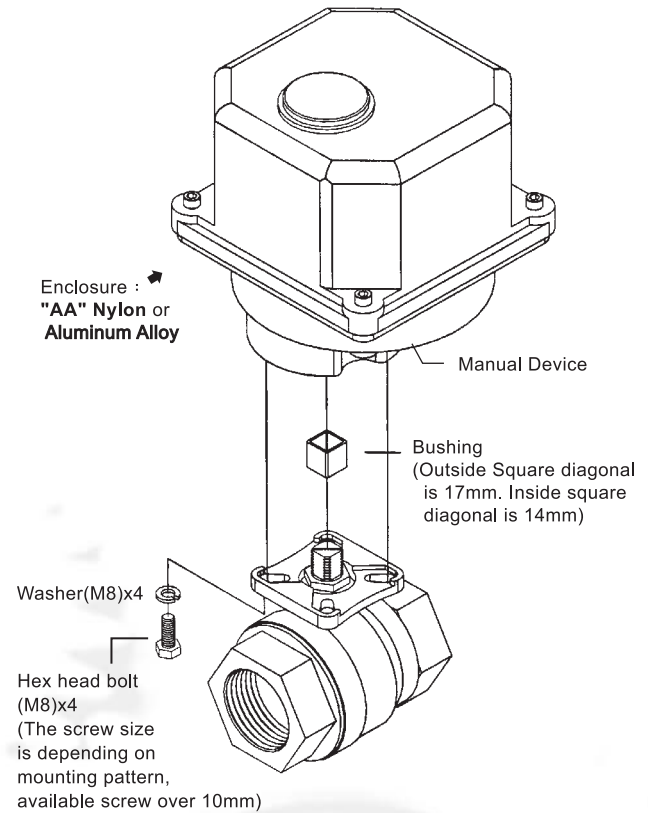
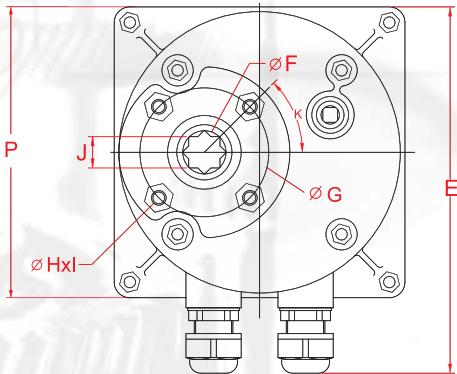

| Dimension (mm) | A | B | C | D | E | F | G | H | I | J | K | L | M | N | O | P | ISO 5211 | |
|----------------|------|-----|-----|----|---|-----|------|----|----|----|----|-----|-----|------|-------|------|----------|-----|
| Model | UM-3 | 165 | 165 | 20 | 8 | 200 | 23.5 | 70 | M8 | M6 | 17 | 45° | 141 | 17.3 | 68.39 | 44.2 | 165 | F07 |